

External Dimensions

ابعاد ظاهری

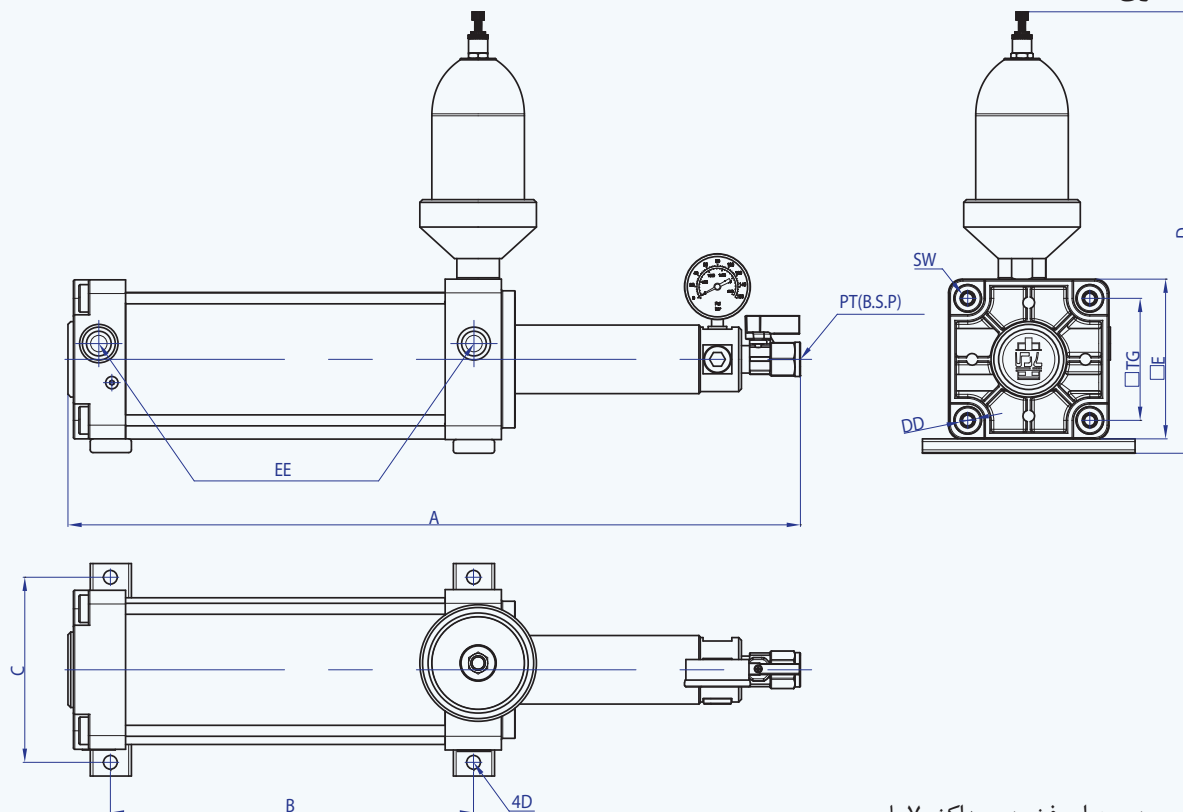

- فشار ورودی هوای فشرده حداکثر ۷ بار
- Maximum input air pressure is 7 bar

Unit: (mm) واحد:

سریال Model	حجم جابجایی مایع Liquid Movement Volume (cc)	فشار خروجی مایع Liquid Output Pressure (bar)	A	B	C	D	ØDD	Ø4d	E	EE	SW	TG	PT
PBP 80 - 25 - 70	25	70	380	210									
PBP 80 - 40 - 100	40	100	410	240	145	302	M10 × 1.5	10	95	G3/8	10	72	G3/8
PBP 80 - 80 - 140	80	140	440	270									
PBP 100 - 80 - 112	80	112	385	230									
PBP 100 - 40 - 175	40	175	415	260	135	316	M10 × 1.5	10	115	G1/2	10	89	G1/2
PBP 100 - 25 - 220	25	220	445	290									
PBP 125 - 128 - 107	128	107	390	240									
PBP 125 - 90 - 122	90	122	420	270	160	349	M12 × 1.75	10	140	G1/2	12	110	G1/2
PBP 125 - 60 - 143	60	143	450	300									
PBP 160 - 200 - 112	200	112	410	260									
PBP 160 - 90 - 145	90	145	440	290	200	384	M16 × 2	10	180	G3/4	14	140	G1/2
PBP 160 - 80 - 175	80	175	470	320									